

# 20R SERIES ROCKING PISTON OIL-LESS PUMPS

## OPERATION & MAINTENANCE MANUAL



Thank you for purchasing this Gast product. It is manufactured to the highest standards using quality materials. Please follow all recommended maintenance, operational and safety instructions and you will receive years of trouble free service.



### WARNING



**PLEASE READ THIS MANUAL COMPLETELY BEFORE INSTALLING AND USING THIS PRODUCT. SAVE THIS MANUAL FOR FUTURE REFERENCE AND KEEP IN THE VICINITY OF THE PRODUCT.**

#### Product Use Criteria:

- Pump only clean, dry air.
- Operate at 32°F - 104°F (0°C - 40°C).
- Protect unit from dirt & moisture.
- Do not pump flammable or explosive gases or use in an atmosphere that contains such gases.
- Protect all surrounding items from exhaust air. This exhaust air can become very hot.
- Corrosive gases and particulate material will damage unit. Water vapor, oil-based contaminants or other liquids must be filtered out.
- Consult your Gast Distributor/Representative before using at high altitudes.
- This pump is oil-less and requires NO lubrication.



ISO 9001 & 14001 CERTIFIED

[www.gastmfg.com](http://www.gastmfg.com)

**Your safety and the safety of others is extremely important.**

We have provided many important safety messages in this manual and on your product. Always read and obey all safety messages.



This is the safety alert symbol. This symbol alerts you to hazards that can kill or hurt you and others. The safety alert symbol and the words "DANGER" and "WARNING" will precede all safety messages. These words mean:



**DANGER**

You will be killed or seriously injured if you don't follow instructions.



**WARNING**

You can be killed or seriously injured if you don't follow instructions.

All safety messages will identify the hazard, tell you how to reduce the chance of injury, and tell you what can happen if the safety instructions are not followed.

## INSTALLATION



**WARNING**



### Electrical Shock Hazard

Disconnect electrical power at the circuit breaker or fuse box before installing this product.

Install this product where it will not come into contact with water or other liquids.

Install this product where it will be weather protected.

Electrically ground this product.

Failure to follow these instructions can result in death, fire or electrical shock.



**WARNING**

Beware of any exposed movable parts. Proper guards should be in place to prevent severe personal injury or death.

**Correct installation is your responsibility.** Make sure you have the proper installation conditions and that installation clearances do not block air flow.

**Blocking air flow over the product in any way can cause the product to overheat.**

### Mounting

Mounting the product to a stable, rigid operating surface and using shock mounts will reduce noise and vibration.

### Plumbing

Connect with pipe and fittings that are the same size or larger than the product's ports. Be sure to connect the intake and exhaust plumbing to the correct inlet and outlet ports. Ports will not support plumbing.

### Accessories

Install gauges in the lines to monitor performance. A relief valve can be installed at the inlet or outlet, or both. Consult a Gast representative for performance limitations.

If operated in a dirt-contaminated atmosphere, a suitable filter should be used to ensure long service. For recommendations, contact a Gast representative.

### Motor Control

**It is your responsibility to contact a qualified electrician and assure that the electrical installation is adequate and in conformance with all national and local codes and ordinances.**

Determine the correct overload setting required to protect the motor (see motor starter manufacturer's recommendations). Select fuses, motor protective switches or thermal protective switches to provide protection. Fuses act as short circuit protection for the motor, not as protection against overload. Incoming line fuses must be able to withstand the motor's starting current. Motor starters with thermal magnetic overload or circuit breakers protect motor from overload or reduced voltage conditions.

The wiring diagram supplied with the product provides required electrical information. Check that power source is correct to properly operate the motors.

NOTE: Standard AC models have either a single-shot or resettable thermal overload. If a motor with a single-shot thermal overload is tripped, it cannot be restarted. A motor with a resettable thermal overload can restart once the motor cools down. The following could possibly cause an overload: a power spike, operating at incorrect voltage, the motor unable to run, or the unit over-heating.

Electrical Connection

**WARNING**

**Electrical Shock Hazard**

**This product must be properly grounded. Do not modify the plug provided. If it will not fit the outlet, have the proper outlet installed by a qualified electrician.**

**If repair or replacement of the cord or plug is necessary, do not connect the grounding wire to either flat blade terminal. The wire with insulation that is green or green with yellow stripes is the grounding wire.**

**Check the condition of the power supply wiring. Do not permanently connect this product to wiring that is not in good condition or is inadequate for the requirements of this product**

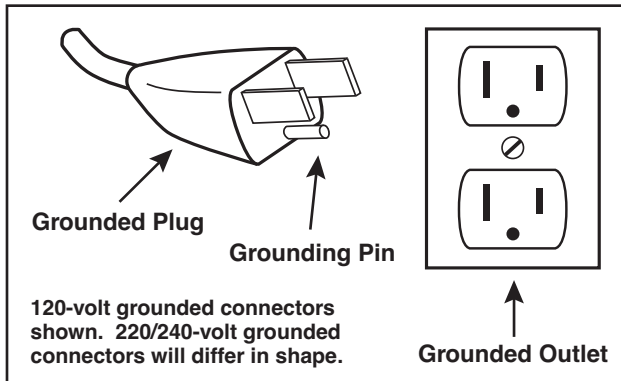

**Model with a power supply cord:**

This product must be grounded. For either 120-volt or 220/240-volt circuits connect power supply cord grounding plug to a matching grounded outlet. Do not use an adapter. (See above diagram.)

**Check with a qualified electrician or serviceman if the grounding instructions are not completely understood, or if you are not sure whether the product is properly grounded. Do not modify the plug provided. If it will not fit the outlet, have the proper outlet installed by a qualified electrician.**

**Model that is permanently wired:**

This product must be connected to a grounded, metallic, permanent wiring system, or an equipment grounding terminal or lead on the product.

Power supply wiring must conform to all required safety codes and be installed by a qualified person. Check that supply voltage agrees with that listed on product nameplate.

DC Wiring

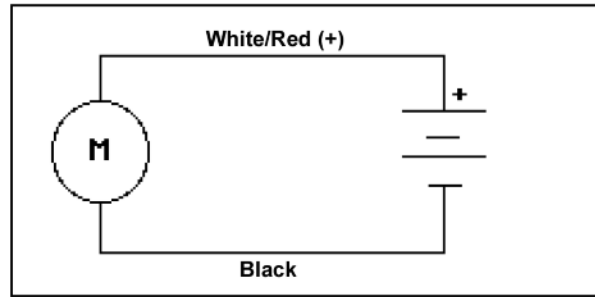

AC Wiring

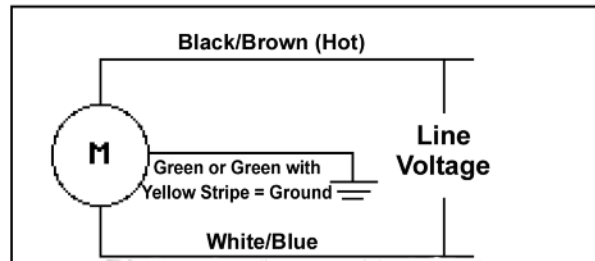

In the event of an electrical short circuit, grounding reduces the risk of electric shock by providing an escape wire for the electric current. This product may be equipped with a power supply cord having a grounding wire with an appropriate grounding plug. The plug must be plugged into an outlet that is properly installed and grounded in accordance with all local codes and ordinances.

**Extension cords:**

Use only a 3-wire extension cord that has a 3-blade grounding plug. Connect extension cord plug to a matching 3-slot receptacle. Do not use an adapter. Make sure your extension cord is in good condition. Check that the gage wire of the extension cord is the correct size wire to carry the current this product will draw.

An undersized cord is a potential fire hazard, and will cause a drop in line voltage resulting in loss of power causing the product to overheat. The following table indicates the correct size cord for length required and the ampere rating listed on the product nameplate. **If in doubt, use the next heavier gage cord. The smaller the gage number, the heavier the wire gage.**

Minimum gage for extension cords										
Amps	Volts	Length of cord in feet								
	120v	25	50	100	150	200	250	300	400	500
	240v	50	100	200	300	400	500	600	800	1000
0-2		18	18	18	16	16	14	14	12	12
2-3		18	18	16	14	14	12	12	10	10
3-4		18	18	16	14	12	12	10	10	8
4-5		18	18	14	12	12	10	10	8	8
5-6		18	16	14	12	10	10	8	8	8
6-8		18	16	12	10	10	8	6	6	6
8-10		18	14	12	10	8	8	6	6	4
10-12		16	14	10	8	8	6	6	4	4
12-14		16	12	10	8	6	6	6	4	2
14-16		16	12	10	8	6	6	4	4	2
16-18		14	12	8	8	6	4	4	2	2
18-20		14	12	8	6	6	4	4	2	2

## OPERATION

### **WARNING**

#### **Injury Hazard**

Install proper safety guards as needed.

Keep fingers and objects away from openings and rotating parts.

When provided, motor terminal covers must be in place for safe operation.

Product surfaces become very hot during operation, allow product surfaces to cool before handling.

Air stream from product may contain solid or liquid material that can result in eye or skin damage, wear proper eye protection.

Wear hearing protection. Sound level from motor may exceed 70 dBA.

Failure to follow these instructions can result in burns, eye injury or other serious injury.

It is your responsibility to operate this product at recommended pressures or vacuum duties and room ambient temperatures. Do not start against a vacuum or pressure load.

#### **Start Up**

If motor fails to start or slows down significantly under load, shut off and disconnect from power supply. Check that the voltage is correct for motor and that motor is turning in the proper direction. Check the plug, cord and switch for damage. The thermal protection switch, if so equipped, may have tripped (if resettable thermal overload, the motor can restart after cooling).

## MAINTENANCE

### **WARNING**



#### **Electrical Shock Hazard**

Disconnect electrical power supply cord before performing maintenance on this product.

If product is hard wired into system, disconnect electrical power at the circuit breaker or fuse box before performing maintenance on this product.

Failure to follow these instructions can result in death, fire or electrical shock.

### **WARNING**

#### **Injury Hazard**

Product surfaces become very hot during operation, allow product surfaces to cool before handling.

Air stream from product may contain solid or liquid material that can result in eye or skin damage, wear proper eye protection.

Clean this product in a well ventilated area.

Failure to follow these instructions can result in burns, eye injury or other serious injury.

It is your responsibility to:

- Regularly inspect and make necessary repairs to product in order to maintain proper operation.
- Make sure that pressure and vacuum are released from product before starting maintenance.

Check intake and exhaust filters after first 500 hours of operation. Clean filters and determine how frequently filters should be checked during future operation. This one procedure will help to assure the product's performance and service life.

1. Correct voltage to the unit.
2. Intake filters - clean or replace.
3. Valves - check for damage or contamination, clean or replace if needed (use a water soluble cleaner only).
4. Piston Cup - check for damage or wear; replace cylinder and/or cup assembly if needed.

**Check that all external accessories such as relief valves and gauges are attached to cover and are not damaged before re-operating product.**

## SHUTDOWN PROCEDURES

It is your responsibility to follow proper shutdown procedures to prevent product damage.  
**NEVER ADD OIL TO THIS OIL-LESS PUMP.**

Proper shutdown procedures must be followed to prevent pump damage. Failure to do so may result in premature pump failure. Gast Manufacturing Rocking Piston Oil-Less Pumps should not be used to pump condensable vapors such as water. Follow the steps below to assure correct storage and shutdown between operating periods.

1. Disconnect plumbing for storage.
2. Operate product for at least 5 minutes without plumbing.
3. Disconnect power supply.
4. Plug open ports to prevent dirt or other contaminants from entering product during storage.

## WARRANTY

Gast finished products, when properly installed and operated under normal conditions of use, are warranted by Gast to be free from defects in material and workmanship for a period of twelve (12) months from the date of purchase from Gast or an authorized Gast Representative or Distributor. In order to obtain performance under this warranty, the buyer must promptly (in no event later than thirty (30) days after discovery of the defect) give written notice of the defect to Gast Manufacturing Incorporated, PO Box 97, Benton Harbor Michigan USA 49023-0097 or an authorized Service Center (unless specifically agreed upon in writing signed by both parties or specified in writing as part of a Gast OEM Quotation). Buyer is responsible for freight charges both to and from Gast in all cases.

This warranty does not apply to electric motors, electrical controls, and gasoline engines not supplied by Gast. Gast's warranties also do not extend to any goods or parts which have been subjected to misuse, lack of maintenance, neglect, damage by accident or transit damage.

THIS EXPRESS WARRANTY EXCLUDES ALL OTHER WARRANTIES OR REPRESENTATIONS EXPRESSED OR IMPLIED BY ANY LITERATURE, DATA, OR PERSON. GAST'S MAXIMUM LIABILITY UNDER THIS EXCLUSIVE REMEDY SHALL NEVER EXCEED THE COST OF THE SUBJECT PRODUCT AND GAST RESERVES THE RIGHT, AT ITS SOLE DISCRETION, TO REFUND THE PURCHASE PRICE IN LIEU OF REPAIR OR REPLACEMENT.

GAST WILL NOT BE RESPONSIBLE OR LIABLE FOR INDIRECT OR CONSEQUENTIAL DAMAGES OF ANY KIND, however arising, including but not limited to those for use of any products, loss of time, inconvenience, lost profit, labor charges, or other incidental or consequential damages with respect to persons, business, or property, whether as a result of breach of warranty, negligence or otherwise. Notwithstanding any other provision of this warranty, BUYER'S REMEDY AGAINST GAST FOR GOODS SUPPLIED OR FOR NON-DELIVERED GOODS OR FAILURE TO FURNISH GOODS, WHETHER OR NOT BASED ON NEGLIGENCE, STRICT LIABILITY OR BREACH OF EXPRESS OR IMPLIED WARRANTY IS LIMITED SOLELY, AT GAST'S OPTION, TO REPLACEMENT OF OR CURE OF SUCH NONCONFORMING OR NON-DELIVERED GOODS OR RETURN OF THE PURCHASE PRICE FOR SUCH GOODS AND IN NO EVENT SHALL EXCEED THE PRICE OR CHARGE FOR SUCH GOODS. GAST EXPRESSLY DISCLAIMS ANY WARRANTY OF MERCHANTABILITY OR FITNESS FOR A PARTICULAR USE OR PURPOSE WITH RESPECT TO THE GOODS SOLD. THERE ARE NO WARRANTIES WHICH EXTEND BEYOND THE DESCRIPTIONS SET FORTH IN THIS WARRANTY, notwithstanding any knowledge of Gast regarding the use or uses intended to be made of goods, proposed changes or additions to goods, or any assistance or suggestions that may have been made by Gast personnel.

Unauthorized extensions of warranties by the customer shall remain the customer's responsibility.

CUSTOMER IS RESPONSIBLE FOR DETERMINING THE SUITABILITY OF GAST PRODUCTS FOR CUSTOMER'S USE OR RESALE, OR FOR INCORPORATING THEM INTO OBJECTS OR APPLICATIONS WHICH CUSTOMER DESIGNS, ASSEMBLES, CONSTRUCTS OR MANUFACTURES.

This warranty can be modified only by authorized Gast personnel by signing a specific, written description of any modifications.

# EXPLODED PRODUCT VIEW, PARTS & ORDERING INFORMATION

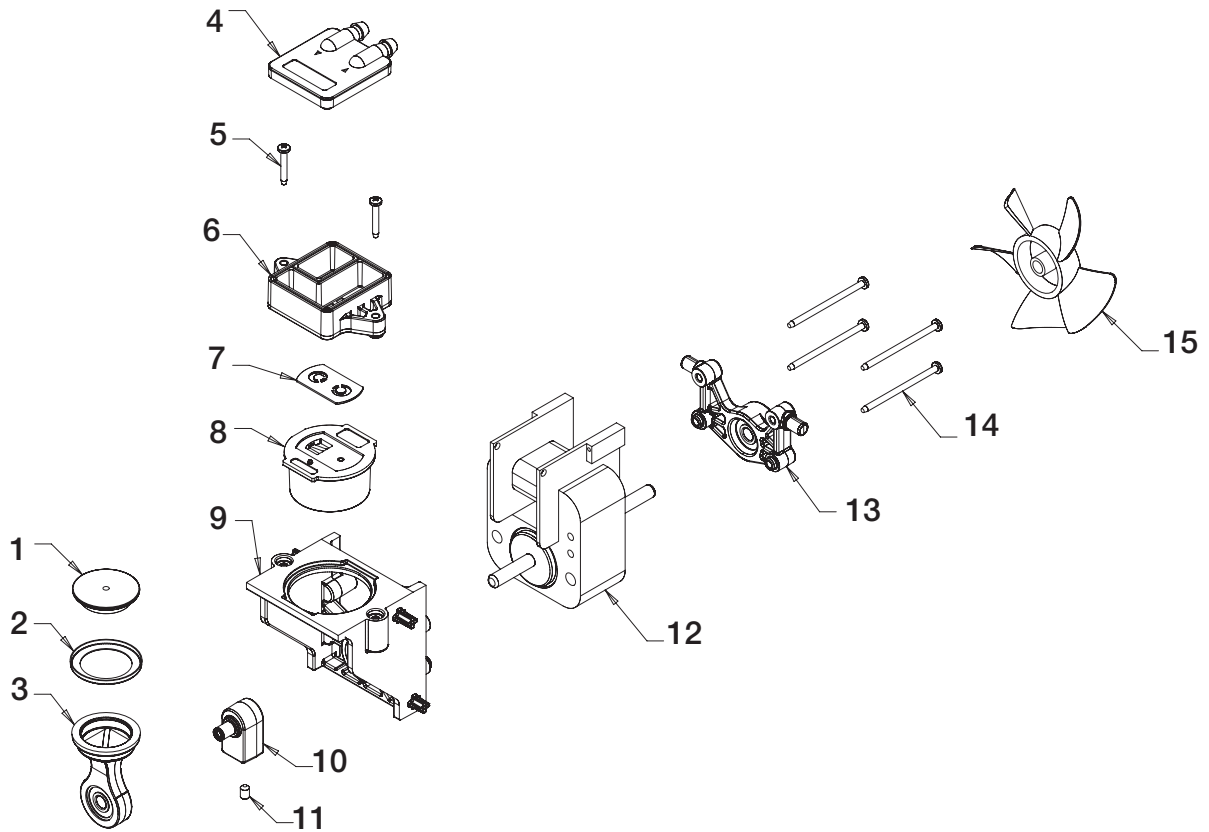

REF	DESCRIPTION	QTY	20R
1	RETAINER PLATE	1	RPL1007
2	CUP	1	CUP1002
3	CONNECTING ROD	1	CNR1010
4	HEAD	1	HDC1013
5	HEAD SCREWS	2	BB937
6	VALVE PLATE	1	VPL1011
7	VALVE	1	VLV1016
8	CYLINDER	1	CYL1000
9	FRONT BRACKET	1	BKT1016
10 *	CRANK	1	CRK1000
11	CRANK SET SCREW	1	BB936
12 *	MOTOR	1	MTR1090
13	REAR BRACKET	1	BKT1017
14 *	MOTOR BOLTS	4	BB938
15 *	FAN	1	ACC1162

Parts listed are for stock models. For specific OEM models, please consult the factory.

When corresponding or ordering parts, please give complete model and serial numbers.

\* Consult factory before ordering

## TROUBLESHOOTING CHART

Low		High		Pump Overheat	Won't Start	Excess Noise	Reason and remedy for problem.
Vacuum	Pressure	Vacuum	Pressure				
•	•	•			•		Filter dirty. Clean or replace.
•	•		•		•		Muffler dirty. Clean or replace.
•	•						Valves dirty or damaged. Clean or replace.
•	•						Worn cup. Repair or replace.
			•		•		Relief valve set too high. Inspect and adjust.
•	•						Relief valve set too low. Inspect and adjust.
•	•	•	•		•		Plugged vacuum/pressure line. Inspect and repair.
•		•					Collapsed vacuum line. Inspect and repair.
				•	•		Low voltage, won't start. Check power source.
				•	•	•	Voltage wrong. Check power source.
•	•					•	Worn cup/piston hitting cylinder. Replace.
•	•				•		Leaky hose or check valve. Replace.
•	•			•	•	•	Dirt or liquid on top of piston. Inspect and clean.
•	•			•	•	•	Motor not wired correctly. Check wiring diagram/line voltage.

For repair parts ordering information and exploded product view, visit our website or call us at the number listed below.

We have Gast Authorized Repair Facilities throughout the world. For the most up-to-date listing, contact one of our sales offices below:

**Gast Manufacturing, Inc.**

P.O. Box 97  
2300 S. Highway M139  
Benton Harbor, MI 49023-0097  
Ph: 269/926-6171  
FAX: 269/925-8288  
www.gastmfg.com

**Gast Hong Kong**

Room 6,9/F  
New Commerce Centre  
19 on Sum Street, Shatin  
N. T. Hong Kong  
Ph: (852) 2690 1066  
Fax: (852) 2690 1012  
www.gasthk.com

**Gast Group Limited, United Kingdom**

Unit 11, The I O Centre  
Nash Road  
Redditch, B98 7AS  
United Kingdom  
ph: +44 (0) 1527 504040  
Fax: +44 (0) 1527 525262  
www.gastmfg.com



ISO 9001 & 14001 CERTIFIED

[www.gastmfg.com](http://www.gastmfg.com)